



indra

DEFENSE AND SECURITY

ALQ-500P ESM/ECM AIRBORNE POD

Defense and security systems in five continents

indracompany.com

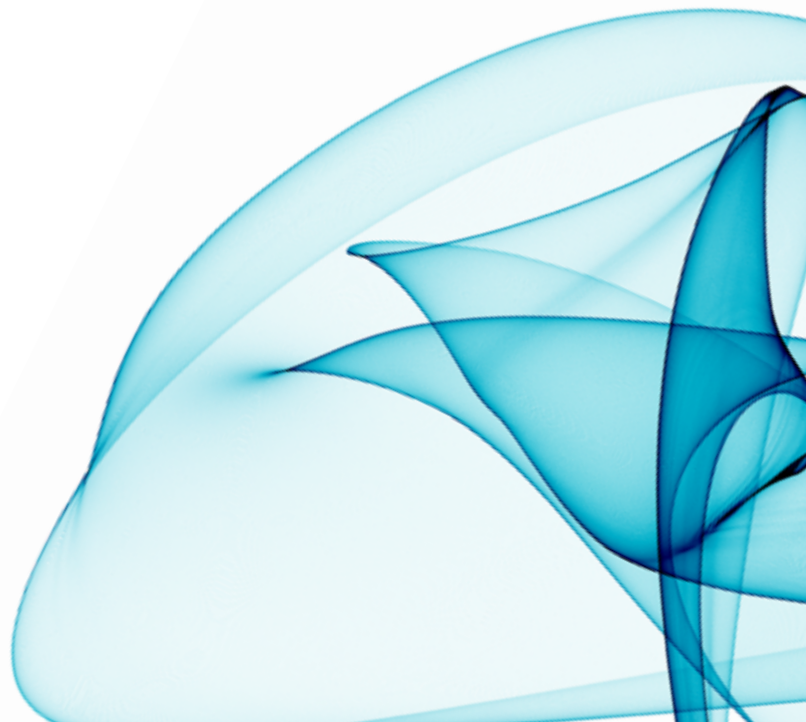

ALQ-500P ESM/ECM AIRBORNE POD



The ALQ-500P represents the latest generation ESM/ECM airborne pod from Indra, based on our proven wide-band DRFM enabling the generation of the most modern electronic countermeasure techniques.

Fully integrated with the Wide Band Digital Radar Warning Receiver ALR-400 enhancing survivability in complex scenarios.

Multi-threat capability with library programmed techniques.

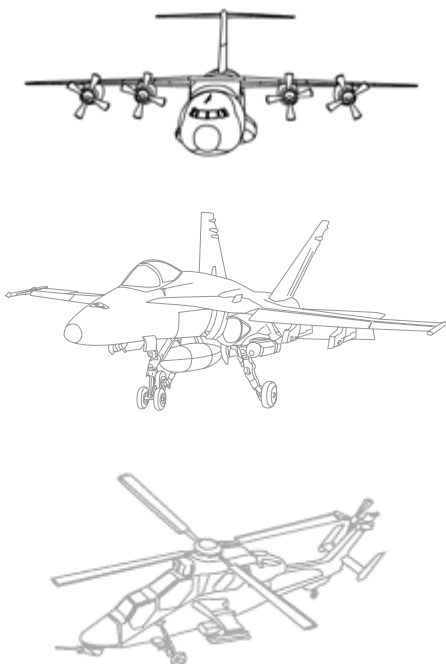

MISSION

The ALQ-500P belongs to the latest generation of airborne radar-band warning and countermeasure subsystems based on the development of high-speed digitization techniques with respect to its analogue predecessors. This new system benefits from all the "know-how" gained up to now in the field of ESM/ECM systems as well as in the advances made in fast digitization and signal digital processing.

From the beginning of its conception, the design has considered current and future trends of NATO countries regarding radar band ESM/ECM systems and their interfaces with other systems. As fundamental concept of future evolution, it has been designed according to a modular architecture easily extendable from the same core process and techniques generation.

CAPABILITIES

- Flexible hardware Architecture: operating modes can be modified by loading new software.
- Wide Band Operation for noise generation and Narrow Band Operation for coherent techniques.
- Use of advanced modern DRFM techniques.
- Multi-Threat capability.
- Generation of Doppler shift techniques
- Large variety of jamming/deceiving techniques in speed, distance, angle and coherent range and velocity.
- Several false targets over threat radars generation capability.
- Stand-Off-Jamming capability.

CONFIGURATION

Aeromechanical Structure

Integrating all system components: LRUs, cabling, cooling distribution as well as the RF antenna assembly units.

ESM Processor

Represents the core of the ESM reception system based in the ALR-400 RWR technology. Centralizes the communications with other systems. Includes both software and radiofrequency process.

ECM Processor

Constitutes the core of the ECM system. Performs Power Management function and time and resources assignation, generates countermeasure parameters and controls the resources to implement them. It is based on DRFM technology.

High Power RF Transmitters

Amplifies the signals generated in the ECM Processor. The power is customizable according to customer needs.

Cockpit Control Unit

The system can operate autonomously through provided cockpit control unit and dedicated display, or it can be integrated with the rest of the A/C avionics & mission system. Different operation modes of the System can be controlled. Several system status luminous indicators are provided.

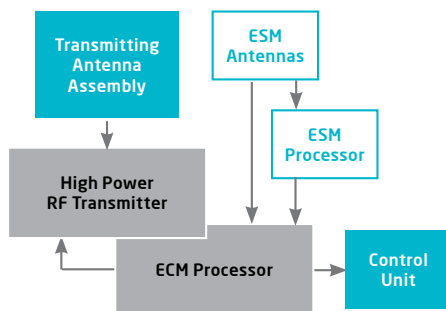

PHYSICAL CHARACTERISTICS

	W x H x D	WEIGHT/unit
ALQ-500P Airborne POD System	3300x340x480mm	284 Kg.
Cockpit Control Unit	145x46x136mm	0,85 Kg.

MAIN STANDARDS

	W x H x D
Environment specification	MIL-STD-810/F
EMI/EMC	MIL-STD-461/F
Power supply	According MIL-STD 1399 adaptable to the Customer
Aircraft mechanical interface	MIL-STD-8591/H
Aircraft electrical interface	MIL-STD-1760/C

OPERATIONAL FEATURES

Radar Threats Awareness

Emission detections and automatic identification by embedded RWR/ESM system. Awareness of the situation to the pilot. Automatic command of countermeasures according to library programming.

Automatic countermeasure management

The countermeasure execution will be performed automatically. There are two different types of countermeasure techniques:

- Deceptive Techniques.
- Jamming Techniques.

A/C Installation

- The ALQ-500P can be installed under wing or belly and fulfills the stores interface MIL-STD-1760C.

Upload threats & countermeasures libraries

- Implemented by means of auxiliary equipment that allows loading threats & countermeasure libraries on ground.
- Optionally, it is possible to load threat & countermeasure libraries by means of insertion of pre-programmed Compact Flash card in specific cockpit device.

EW Management

The ALQ-500P can operate totally autonomously or can also interface with Chaff & Flares subsystem already installed in the A/C, deciding the most convenient program (ECM, Chaff or combined) at a time according to a pre-programmed library.

Interface with other systems

- Interfaces with other EW systems (data interface MIL-STD-1553B).



TECHNOLOGICAL ADVANTAGES

Countermeasures techniques

- Tailored and combined countermeasures capability (CM generated exclusively by ALQ-500P or by ALQ-500P + CFD system).
- Jamming Techniques: SJAM, BJAM, NCP, HDT.
- Deception Techniques: RGPO, RGPI, RANRAP, VGPO, VGPI, SVGPO, VN, VFT, NCP, HDT, HDC.

TECHNICAL SPECIFICATION

- **Frequency coverage:** From 2 to 18 GHz (configurable).
- **Transmission Power:** Configurable.
- **Multi-threat jamming:** Up to 8 simultaneous threats.





indra

Avda. de Bruselas, 35.
28108 Alcobendas.
Madrid (Spain)
T +34 91 627 14 50
F +34 91 627 10 07
infodefense@indracompany.com
indracompany.com

Indra reserves the right to
modify these specifications
without prior notice